

**robot coupe®**  
LES OUTILS DU PROFIT

**CL 50**

Voltages	Dernier numéro de fabrication	Date d'arrêt de la fabrication
<i>Voltages</i>	<i>Last serial number</i>	<i>Discontinued date</i>
220 / 50 / 1	92 / 2155	21 / 02 / 1989
240 / 50 / 1	92 / 2140	21 / 02 / 1989
115 / 60 / 1	92 / 1929	12 / 12 / 1989

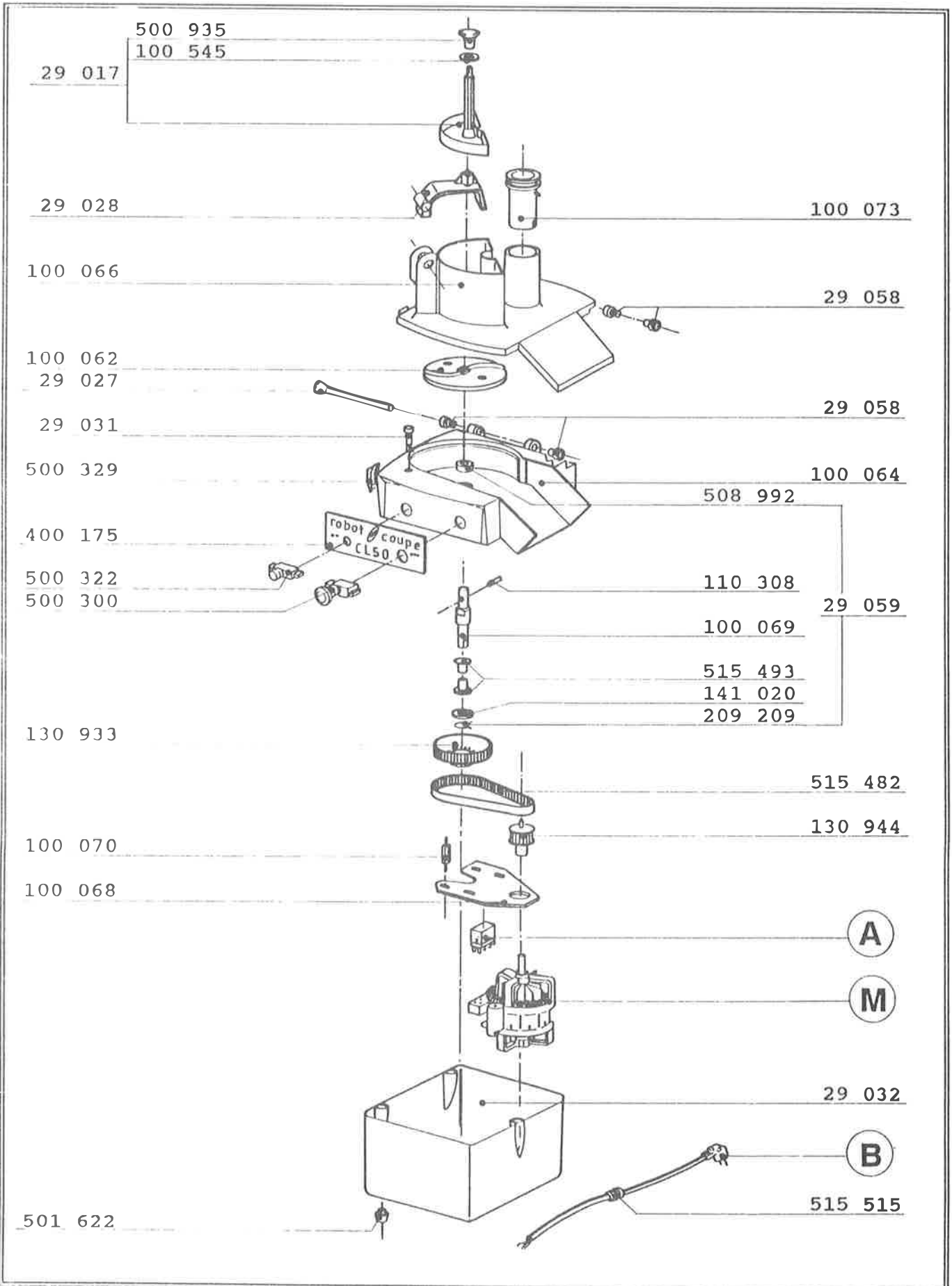

**A**

RELAIS SECURITE / SECURITY RELAY

**B**

CABLE D'ALIMENTATION / POWER CORD

**M**

MOTEUR / MOTOR



CONDENSATEUR MOTEUR / MOTOR CAPACITOR





RELAIS MOTEUR / MOTOR RELAY

REFERENCE	DESIGNATION
29 017	ENS POUSSOIR LEGUMES / VEGETABLE PUSHER ASS
29 027	ENS TIGE VERROUILLAGE / LOCKING ROD ASS
29 028	ENS GUIDE POUSSOIR LEGU / PUSHER GUIDE ASS
29 031	ENS I L S AVEC SUPPORT / REED SWITCH ASS
29 032	ENS CAPOT AVEC PIEDS / BASE WITH FEET ASS
29 058	ENS BAGUES EPAULEES (4) / SHOULDERED RING ASS (4)
29 059	ENS ARBRE DE TRANSMISSION / TRANSMISSION SHAFT ASS
100 062	DISQUE EVACUATEUR / DISCHARGE PLATE
100 064	CUVE COUPE LEGUMES / VEGETABLE SLICER BOWL
100 066	COUVERCLE COUPE LEGUMES / VEGETABLE SLICER LID
100 068	PLAQUE SUPPORT MOTEUR / MOTOR SUPPORT PLATE
100 069	ARBRE DE TRANSMISSION / SHAFT
100 070	ENTRETOISE / BRACE
100 073	POUSSOIR CAROTTES / CARROT PUSHER
100 545	RONDELLE BUTEE / THRUST WASHER
110 308	GOUPILLE D'AXE MOTEUR / MOTOR SHAFT PIN
130 933	POULIE DENTEE 75 DENTS / PULLEY ( 75 teeth )
130 944	POULIE MOTRICE 20 DENTS / PULLEY ( 20 teeth )
141 020	RONDELLE DE FROTTEMENT / RUBBING WASHER
209 209	CIRCLIPS / BUSHING
400 175	PLAQUE FRONTALE / FRONT PLATE
500 300	BOUTON ROUGE / RED KNOB
500 322	BOUTON VERT / GREEN KNOB
500 329	GRENOUILLERE / CLIP
500 935	POIGNEE FIXE / HANDLE KNOB
501 622	PIEDS BLANC / WHITE FOOT
508 992	BAGUE D'ETANCHEITE / SEAL RING
515 482	COURROIE / BELT
515 493	BAGUE AUTO-LUBRIFIANTE / RING
515 515	PRESSE ETOUPE / CORD PROTECTOR



CL 50



N°	M	V	H <sup>Z</sup>			A	B
24 018	3009	220	50	600 018	500 289	509 124	507 320
24 019	3010	240	50	600 018	500 289	509 124	507 320
24 020	3011	115	60	603 669	500 296	509 135	503 206

## # MACEDOINE / DICING GRIDS

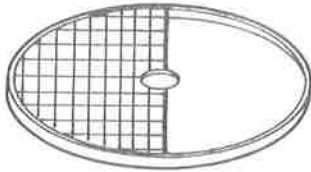
**CL 50**

28 010	: 5 x 5
28 011	: 8 x 8
28 012	: 10 x 10
28 013	: 14 x 14
28 014	: 20 x 20

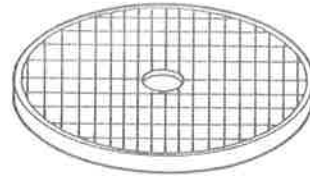
**CL 55/CL 60**

28 369	: 5 x 5
28 370	: 8 x 8
28 380	: 10 x 10
28 391	: 14 x 14
28 402	: 20 x 20

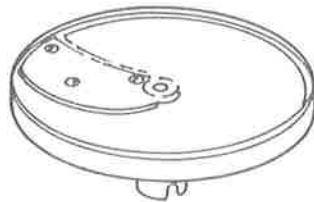
**EMINCEUR SIMPLE COUPE / SLICER SIMPLE CUT**

	POUR ANCIEN DISQUE FOR OLD STYLE DISC	MOYEN HEXAGONAL HEXAGONAL HUB	MOYEN ROND ROUND HUB
EMINCEUR/5mm/SLICER LAME/ BLADE	- 141 120	27 035 100 722	28 065 100 722
EMINCEUR/8mm/SLICER LAME/BLADE	- 141 120	27 036# 100 722	28 066# 100 722
EMINCEUR/10mm/SLICER LAME/BLADE	- 141 120	27 037# 100 722	28 067# 100 722
EMINCEUR/14mm/SLICER LAME/BLADE	- 141 120	27 039# 100 722	28 068# 100 722
POMMES ONDULEES/5mm/RIPPLE CUT LAME/BLADE	- -	- -	27 070 101 352

# Eminceur à combiner avec  
grille de même dimension# Slicer to be combined with  
grid of same dimension

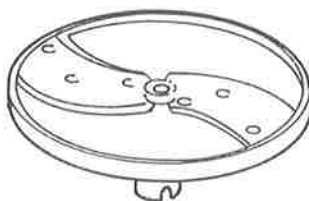
**EMINCEUR DOUBLE COUPE / SLICER DOUBLE CUT**

	POUR ANCIEN DISQUE FOR OLD STYLE DISC	MOYEN HEXAGONAL HEXAGONAL HUB	MOYEN ROND ROUND HUB
EMINCEUR/1mm/SLICER LAME/BLADE	- 141 130	27 032 100 722	28 062 100 722
EMINCEUR/2mm/SLICER LAME/BLADE	- 141 120	27 033 100 722	28 063 100 722
EMINCEUR/3mm/SLICER LAME/ BLADE	- 141 120	27 034 100 722	28 064 100 722
POMMES ONDULEES/2mm/RIPPLE CUT LAME/BLADE	- -	- -	27 068 101 352
POMMES ONDULEES/3mm/RIPPLE CUT LAME/BLADE	- -	- -	27 069 101 352

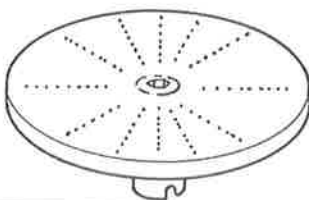
**RAPEUR / GRATERS**

	MOYEN HEXAGONAL HEXAGONAL HUB	MOYEN ROND ROUND HUB
RAPEUR RADIS/RADISH GRATER	28 436	28 055
RAPEUR/1,5mm/GRATER	28 270	28 056
RAPEUR/2mm/GRATER	28 261	28 057
RAPEUR/3mm/GRATER	28 260	28 058
RAPEUR/5mm/GRATER	28 281	28 059
RAPEUR/7mm/GRATER	-	28 016
RAPEUR/9mm/GRATER	28 292	28 060
PARMESAN/PARMESAN	28 435	28 061

## BATONNET / SQUARE JULIENNE

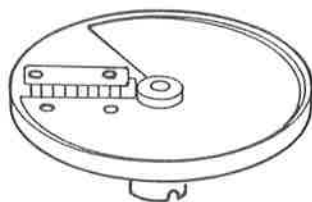

	POUR ANCIEN DISQUE FOR OLD STYLE DISC	MOYEN HEXAGONAL HEXAGONAL HUB	MOYEN ROND ROUND HUB
JULIENNE 2 x 2 PEIGNE/COMB LAME/BLADE	- 126 104 141 141	27 040 100 756 100 764	28 051 100 756 100 764
JULIENNE 2 x 4 PEIGNE/COMB LAME/BLADE	- - -	- - -	27 072 101 463 100 764
JULIENNE 2 x 6 PEIGNE/COMB LAME/BLADE	- - -	- - -	27 066 101 440 100 764
JULIENNE 2 x 8 PEIGNE/COMB LAME/BLADE	- - -	- - -	27 067 101 441 100 764
JULIENNE 4 x 4 PEIGNE/COMB LAME/BLADE	- - -	27 041 100 757 100 764	28 052 100 757 100 764
JULIENNE 5 x 5 PEIGNE/COMB LAME/BLADE	- # 141 141	- - -	- - -
JULIENNE 6 x 6 PEIGNE/COMB LAME/BLADE	- - -	27 042 100 758 100 764	28 053 100 758 100 764
JULIENNE 7 x 7 PEIGNE/COMB LAME/BLADE	- # 141 141	- - -	- - -
JULIENNE 8 x 8 PEIGNE/COMB LAME/BLADE	- - -	27 043 100 759 100 764	28 054 100 759 100 764
JULIENNE 9 x 9 PEIGNE/COMB LAME/BLADE	- 126 270 141 141	27 043 100 759 100 764	28 054 100 759 100 764

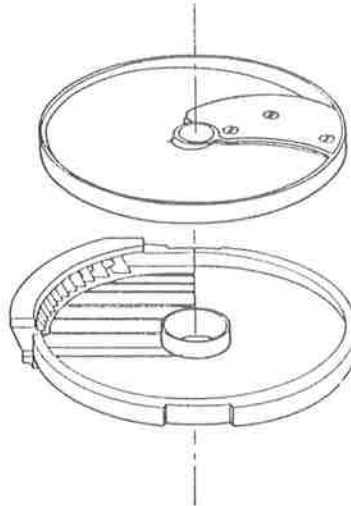
**EQUIPEMENT FRITES / FRENCH FRIES EQUIPMENT**

**CL 50**

28 005	: 6 x 6		
	- EMINCEUR	6 :	29 308
	- GRILLE	6 :	101 644
28 003	: 8 x 8		
	- EMINCEUR	8 :	29 267
	- GRILLE	8 :	101 646
28 009	: 10 x 10		
	- EMINCEUR	10 :	29 276
	- GRILLE	10 :	101 645

**CL 60**

28 078	: 6 x 6		
	- EMINCEUR	6 :	29 308
	- GRILLE	6 :	101 647
28 079	: 8 x 8		
	- EMINCEUR	8 :	29 267
	- GRILLE	8 :	101 648
28 080	: 10 x 10		
	- EMINCEUR	10 :	29 276
	- GRILLE	10 :	101 649